

AT-9534SP

MUFFLER ASSEMBLY, SLIP-ON, SPORT
2020-UP POLARIS SPORTSMAN XP 1000S,
SCRAMBLER XP 1000

MBRP®

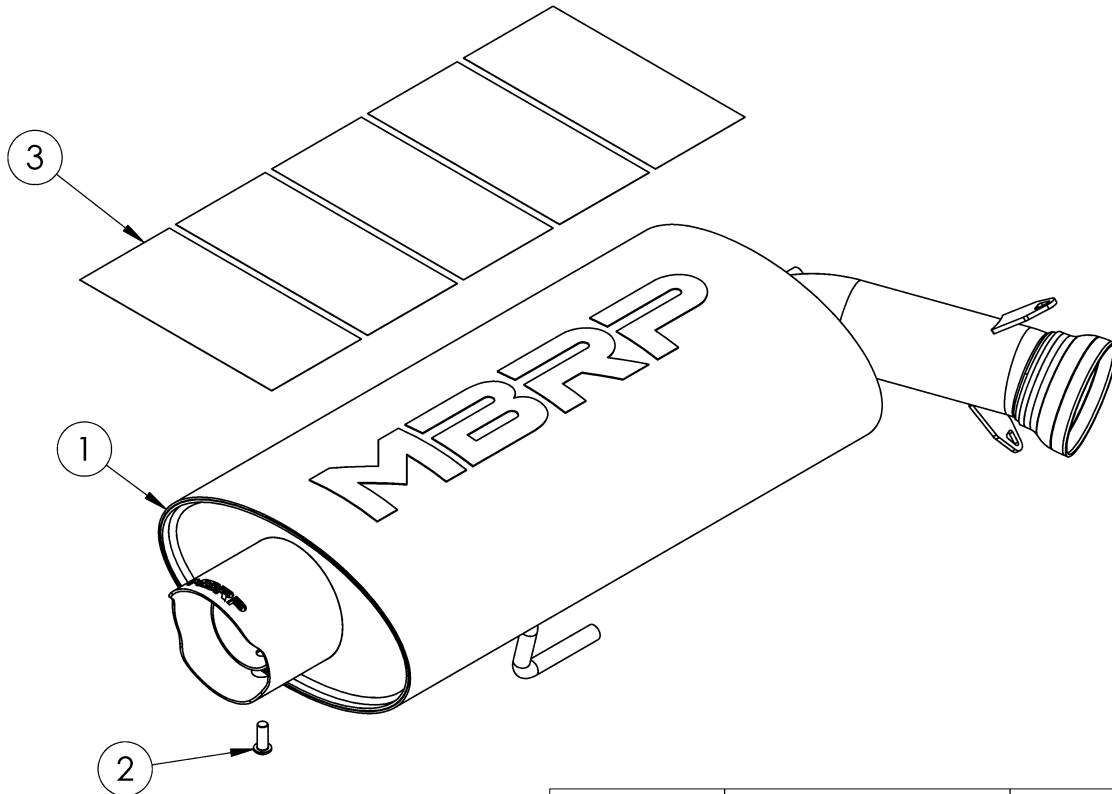

ITEM NO.	DESCRIPTION	QTY.
1	MUFFLER	1
2	SCREW	1
3	FOIL TAPE	5

Refer to this LOT NUMBER when contacting customer service: _____

PLEASE READ BEFORE STARTING INSTALLATION

While MBRP has made every effort to ensure that all components of this system are of superior quality and properly packaged, it is the installer's responsibility to ensure the following before removal of the factory exhaust:

- that ALL components shown above are present.
- that ALL mating components fit together.
- that there are no damaged components.
- that the system you have purchased is appropriate for your vehicle year, model and configuration.
- that the system will not interfere with any modifications previously installed or planned.
- that you have read and understand these instructions.

If you have any questions or are uncertain about any aspect of the installation of this system to your vehicle please contact your dealer before commencing installation.

MBRP

Removal of Stock Exhaust:

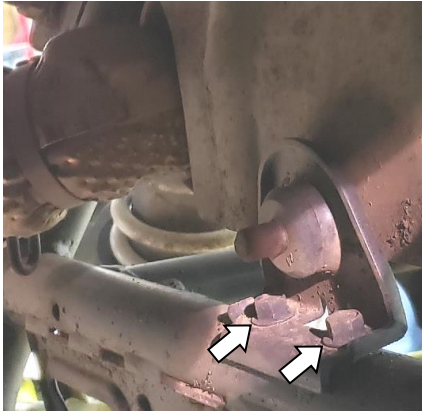

Figure 1



Figure 2

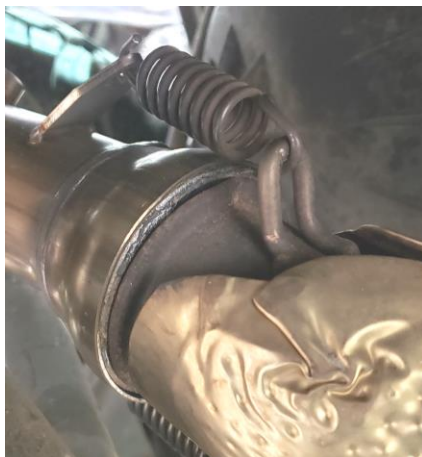

Figure 3

1. Apply penetrating lubricant liberally to all exhaust fasteners, hangers, and rubber isolators.
2. Remove the rear bumper (if equipped).
3. Remove the two (2) springs securing the muffler inlet to the head pipe. Keep the springs as they will be reused with the new system.
4. Loosen and remove the screws (2) securing the front hanger mount to the frame. Slide the mount (isolator and bracket) off the rear exhaust hanger and set it aside to be reused with the new exhaust. **Refer to Figure 1**
5. Carefully slide the stock muffler off the front pipe and slide it rearward, removing it through the center opening of the frame.
6. Ensure that the gasket is not damaged, then leave it on the head pipe for reuse.
7. Remove the stock muffler bezel to access the spark arrestor. Remove the screw and nut that secure the spark arrestor, keeping the nut to reuse. Remove the spark arrestor to reuse it in the new **Muffler Assembly**.

Installation of MBRP Exhaust:

1. Place the spark arrestor into the new **Muffler Assembly** outlet, ensuring that the screw hole is aligned with the hole at the bottom of the outlet. Use the nut removed from the stock assembly and the provided **Screw** to secure the spark arrestor.
2. For Scrambler models, add **Foil Tape** to the plastic drip pan located above the muffler. Sportsman models are already equipped with an adhesive shield, but coverage can be extended forward as desired.
3. Place the **Muffler Assembly** into position through the rear frame opening, sliding the bottom hangers into the isolator mounts. When sliding the **Muffler Assembly** in place, carefully line up the inlet with the stock gasket to avoid damaging the gasket.
4. Slide the front hanger mount onto the front exhaust hanger and reinstall the screws (2) to secure it to the frame. **Refer to Figure 2**
5. Reinstall the two (2) springs to secure the muffler inlet to the header pipe.
6. Finally, replace the rear bumper.

Note: To maintain optimal performance, the spark arrestor screen should be cleaned after the **first 3 hours of use**. Afterwards, clean every 30-35 hours of use.



Congratulations! You are ready to begin experiencing the improved performance and driving excitement of your **MBRP** Ltd. Exhaust upgrade. We know you will enjoy your purchase.